

PAN05-1B/-2B/-3B In Wall Single relay (1 way) switch module

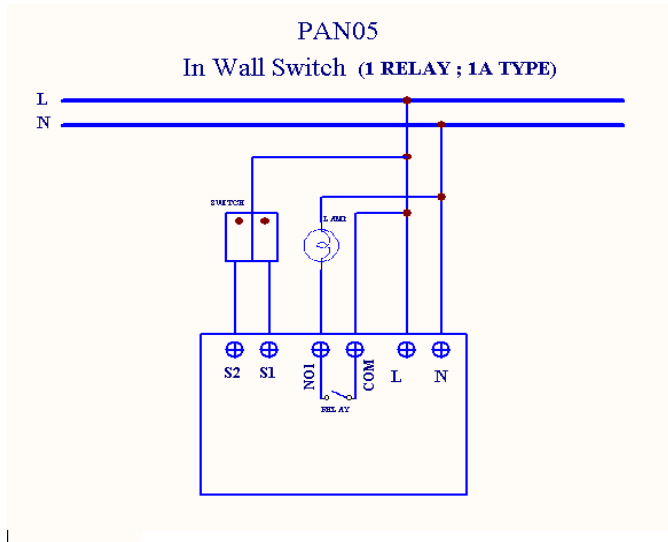
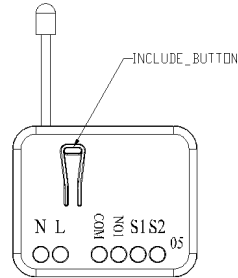
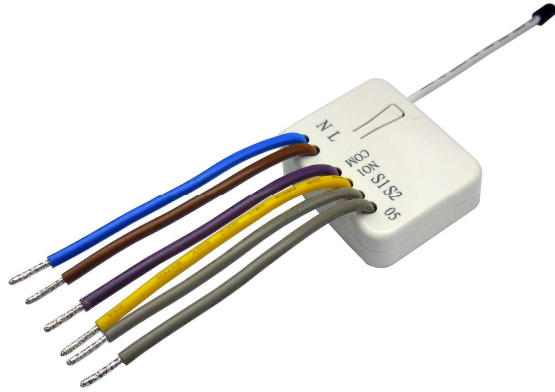

Fig 1. Assembling

This in-wall switch module is a transceiver which is a security enabled device which based on Z-Wave Plus technology, and it is fully compatible with any Z-Wave™ enabled network. Mini size design let the module can easily hide itself into the wall box and that will be good for the house decoration. Since PAN05 supports Security Command Class, it can learn with Secured controller. Its functionality and supported command classes is identical when included as a secure and non-secure device.

There are many kind of application by using the module to switch Load On and Off, one main application is the light control. If connect the **COM** terminal directly to AC Line terminal, the new smart relay calibration technology can reduce the inrush current caused by the load and let the module work perfectly with many kind of light like incandescent, fluorescent and LED light. This module can also connect to alternative power supply like DC 12V to switch on/off 12V MR-16 light as follow picture.



Adding to Z-Wave™ Network

In the front casing, there is an on/off button with LED indicator below which is used to toggle switch on and off or carries out add, remove, reset or association. When first power applied, its LED flashes on and off alternately and repeatedly at 0.5 second intervals. It implies that it has not been assigned a node ID and start auto inclusion.

Auto Inclusion

The function of auto inclusion will be executed as long as the in wall switch does not have Node ID and just connect the switch to main power.

Note: Auto inclusion timeout is 2 minute during which the node information of explorer frame will be emitted once every several seconds. Unlike “Add” function as shown in the table below, the execution of auto inclusion is free from pressing the On/Off button on the Switch.

The table below lists an operation summary of basic Z-Wave functions. Please refer to the instructions for your Z-Wave™ Certificated Primary Controller to access the Setup function, and to Add/Remove/associate devices

Function	Description	Annotation
No node ID	The Z-Wave Controller does not allocate a node ID to the Switch.	LED 2-second on, 2-second off
Add	1. Put your Z-Wave controller into inclusion mode by following the instructions provided by the controller manufacturer.	One press one flash LED
	2. Pressing Include button of PAN05 three times within 2 seconds will enter inclusion mode.	
Remove	1. Put your Z-Wave controller into exclusion mode by following the instructions provided by the controller manufacturer.	One press one flash LED
	2. Pressing Include button of PAN05 three times within 2 seconds will enter exclusion mode.	
	3. Node ID has been excluded.	0.5s On, 0.5s Off (Enter auto inclusion)
Reset	1. Pressing Include button of PAN05 three times within 2 seconds will enter inclusion mode.	Use this procedure only in the event that the primary controller is lost or

	2. Within 1 second, press Include button of PAN05 again for 5 seconds.	otherwise inoperable.
	3. IDs are excluded.	0.5s On, 0.5s Off (Enter auto inclusion)
Association	1. The PAN05 is an always listening Z-Wave device, so associations may be added or removed by a controller at any time. Or If your controller requires to have the PAN05 send a 'node information frame' or NIF for associations, then pressing the On/Off button three times within 2 seconds will cause the PAN05 to send its NIF.	
	2. There are only one group for the switch	
※Adding a node ID allocated by Z-Wave Controller means inclusion. Removing a node ID allocated by Z-Wave Controller means exclusion. ※Failed or success in adding/removing the node ID can be viewed from the Z-Wave Controller.		

Sometimes people are not easy to execute add or remove especially when PAN05 already installed in a wall box. To solve this issue, PAN05 support a special feature that can use S1 or S2 to execute “add, remove, Reset or Association” at the first 3 minutes when first time connect to main power.

LED Indication

To distinguish what mode the switch is in, view from the LED for identification.

State Type	LED Indication
Normal	Whenever we switch On and off of the PAN05 by S1 S2 or On/Off button or RF command, the LED will lights up when switch on; whereas LED off when switch off.
No node ID	Under normal operation, when the Switch has not been allocated a node ID, the LED flashes on and off alternately at 2-second intervals. By pressing S1 S2 or On/Off button, it will stop flashing temporarily.
Learning	When PAN05 is in learning mode, LED flashes on and off alternately and repeatedly at 0.5 second intervals.

Overload	When overload state occurs, the Switch is disabled of which LED flashes on and off alternately at 0.2 second intervals. Overload state can be cleared by disconnect and reconnect the Switch to the main power.
----------	---

Choosing a Suitable Location

1. Do not locate the Switch facing direct sunlight, humid or dusty place.
2. The suitable ambient temperature for the Switch is 0°C~40°C.
3. Do not locate the Switch where exists combustible substances or any source of heat, e.g. fires, radiators, boiler etc.
4. After putting it into use, the body of Switch will become a little bit hot of which phenomenon is normal.

Installation

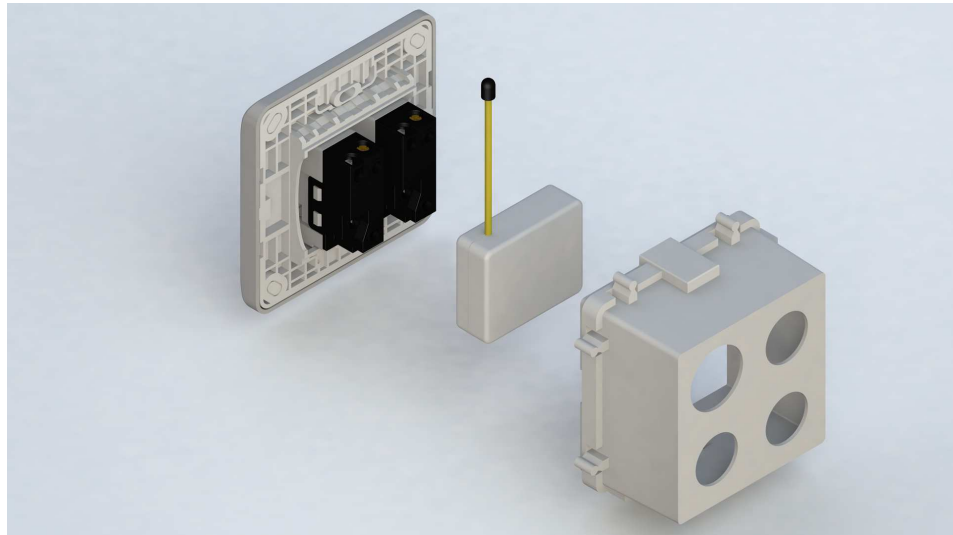

1. Put the in wall switch into a wall box and connect the AC power wire L, N to PAN05 connector L, N.
2. Connect the wall switch to the PAN05 as Fig1.

3. There are 3 mode PAN05 can be configured to match different kind of wall switch, please refer to **3-1 Edge / Pulse / Edge-Toggle mode** which described in next section of this user manual.
4. If Edge-Toggle mode has been set, and the S1 S2 is connect to normal bi-stable switch, every time when change the state of the wall switch will also swap the state of Relay1.

Programming

1. Basic Command Class / Binary Switch Command Class

The Switch will respond to BASIC and BINARY commands that are part of the Z-Wave system.

1-1 BASIC_GET / BINARY_SWITCH_GET

Basic Get Command: [Command Class Basic, Basic Get]
Basic Report Command: Report OFF: [Command Class Basic, Basic Report, Value = 0(0x00)] Report ON: [Command Class Basic, Basic Report, Value = 255(0xFF)]

Binary Switch Get Command: [Command Class Switch Binary, Switch Binary Get]
Binary Switch Report Command: Report OFF: [Command Class Switch Binary, Switch Binary Report, Value = 0(0x00)] Report ON: [Command Class Switch Binary, Switch Binary Report, Value = 255(0xFF)]

1-2 BASIC_SET / SWITCH_BINARY_SET

[Command Class Basic, Basic Set, Value = 1~99, 255(0xFF)] : the load attached to the Switch turns on.
[Command Class Basic, Basic Set, Value = 0(0x00)] : the load attached to the Switch turns off.
[Command Class Switch Binary, Switch Binary Set, Value = 1~99, 255(0xFF)] : the load attached to the Switch turns on.
[Command Class Switch Binary, Switch Binary Set, Value = 0(0x00)] : the load attached to the Switch turns off.

1. Z-Wave's Groups (Association Command Class Version 2)

The Switch can be set to send reports to associated Z-Wave devices. It supports only one association group and the group has one node support. Group1 support SWITCH_BINARY_REPORT.

For group 1, the Switch will report ON/OFF status of Relay to controller.

2-1 Auto report to Grouping 1 (Maximum Node 1)

2-1-1 On/Off Event Report

When "on" or "off" state has been changed (ex. Press S1 S2 or include on/off button), it will send Binary Switch Report to the nodes of Group1.

Binary Switch Report

ON:[Command Class Switch Binary, Switch Binary Report, Value = (255)0xFF]
 OFF:[Command Class Switch Binary, Switch Binary Report, Value = 0(0x00)]

2-1-2 Overload alarm report command

When PAN05 detect the overload, it will send Alarm Report to the node of Group1.

The content of Alarm Report

Alarm report command:[Command Class Alarm, Alarm Report, Alarm Type = 0x08, Alarm Level = 0xFF]

2. Z-Wave's Configuration

Configuration Parameter	Function	Size (Byte)	Value	Unit	Default	Description
1	Edge or Pulse mode or Edge-Toggle mode	1	1-3		1	1 : Edge mode 2 : Pulse mode 3 : Edge-Toggle mode

2	Restore switch state mode	1	0-2		1	0 : Switch Off 1 : Last Switch State 2 : Switch On
3	Manual On/Off mode	1	0-1		1	0 : Disable manual On/Off 1 : Enable manual On/Off
4	LED indication mode	1	1-3		1	1 : Show switch state 2 : Show night mode 3 : One flash mode
5	Auto off timer	2	0-0x7FFF	Second	0	0 : Disable auto off function 1-0x7FFF : 1 ~ 32767seconds
6	RF Off command mode	1	0-3		0	0 : Switch off 1 : Ignore 2 : Switch toggle 3 : Switch on
11	Manual Switch Report mode	1	0-1		1	0 : Disable 1 : Enable

3-1 Edge / Pulse / Edge-Toggle mode

Manual switch S1 and S2 can set to Edge mode or Pulse mode or Edge-Toggle mode, default value is Edge mode.

3-1-1 Edge mode: this mode is suitable for the bi stable wall switch that has indicator point on the switch, and the same position correspond to same state of relay1. if the PAN05 relay change the state because of receiving Z-Wave RF command, it may need two times of change (switch on to off or switch off to on) to let relay back to the correspond state. **Manual switch S2 is disabled in this mode.**

3-1-2 Pulse mode: this mode is suitable for the toggle type wall switch to swap the state of Relay1.

3-1-3 Edge-Toggle mode: this mode is suitable for the normal bi-stable switch, every time when change the state of the wall switch will also swap the state of Relay1.

3-2 Restore Switch State Mode

Whenever the AC power reconnected to PAN05, it will set the switch to Off · On or Last switch state, default value is Last switch state.

3-3 Manual On/Off Mode

The On/Off function of S1 · S2 and learn switch can be disabled or enabled by this parameter, default value is Enable. But the learning operation won't be affected. When manual On/Off function is disabled, the RF command can only switch On but not Off. This is useful function for keeping the device in switch on state.

3-4 LED indication Mode

3-4-1 Show switch state : LED on for switch on and off for switch off. The default value is Show switch state.

3-4-2 Show night mode : LED off for switch on and on for switch off.

3-4-3 One Flash mode : When the state of switch changes, LED will be on only one second, then LED keeps off.

3-5 Auto Off timer

When auto off timer is equal to 0, the auto off function will be disabled. Whenever the switch is set to on, the auto off timer begin to count down. After the timer counts to zero, PAN05 will switch off automatically. The default value is disable auto off function.

3-6 RF Off command mode

Whenever a RF Off command is received, BASIC_SET · BINARY_SWITCH_SET ·

SWITCH_ALL_OFF, it could be interpreted as Switch Off · Switch On · Switch Toggle, or it would be ignored. The default value is Switch Off.

3-7 Manual Switch Report mode :

Whenever PAN11 is manually switch on or off, it will send BINARY_SWITCH_REPORT to the node of group1. The default setting is Enable the function.

4. Protection Command Classes

PAN05 supports Protection Command Class version 2, it can protect the switch against unintentionally control by e.g. a child. And it can also protect the switch from being turned off by setting it in “No RF Control” state.

After being set to “Protection by sequence” state, any intentional pressing of On/Off button or S1/S2 should be hold longer than 1 second, or the switch state will not change.

However, the operation of learn function does not change, because learning will not be protected.

5. Command Classes

The Switch supports Command Classes including...

- * COMMAND_CLASS_ZWAVEPLUS_INFO_V2
- * COMMAND_CLASS_VERSION_V2
- * COMMAND_CLASS_MANUFACTURER_SPECIFIC_V2
- * COMMAND_CLASS_SECURITY
- * COMMAND_CLASS_DEVICE_RESET_LOCALLY
- * COMMAND_CLASS_ASSOCIATION_V2
- * COMMAND_CLASS_ASSOCIATION_GRP_INFO
- * COMMAND_CLASS_POWERLEVEL
- * COMMAND_CLASS_SWITCH_BINARY
- * COMMAND_CLASS_BASIC
- * COMMAND_CLASS_SWITCH_ALL
- * COMMAND_CLASS_CONFIGURATION
- * COMMAND_CLASS_ALARM
- * COMMAND_CLASS_PROTECTION_V2

Troubleshooting

Symptom	Cause of Failure	Recommendation
The Switch not working and LED off	1. The Switch is not connect to the Main power 2. The Switch break down	1. Check power connections 2. Don't open up the Switch and send it for repair.
The Switch LED illuminating, but cannot control the ON/OFF Switch of the load attached	Check if the load connect into the Switch has its own ON/OFF switch	Set the ON/OFF switch of the load attached to ON
The Switch LED illuminating, but the detector cannot control the Switch	1. Not carry out association 2. Same frequency interference	1. Carry out association 2. Wait for a while to re-try
LED keep flashing continuously, but cannot control	Overload occurs	Remove the load attached or check max. load cannot exceed 85 °C (230Vac/120Vac) (Resistive load)

Specification

Operating Voltage	100 ~240VAC /50Hz/60Hz
Maximum Load	11A (230Vac/120Vac) (Resistive load)
Range	Minimum 40 m in door 100m outdoor line of sight
Operating Temperature	0°C ~ 40°C
Frequency Range	PAN05-1: 868.40MHz; 869.85MHz(EU) / PAN05-2: 908.40MHz; 916.00MHz(USA/Canada) / PAN05-3: 922.5MHz/ 923.9MHz/ 926.3MHz (Taiwan/JP)

** Specifications are subject to change and improvement without notice.



FCC ID : RHHPAN05

Warning:

1. Plug out to disconnect from power supply; do not plug in line.
2. Do not exceed the max rating

Disposal

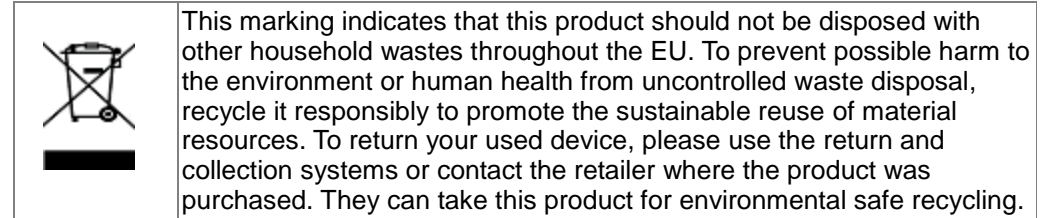

Company of License Holder : Philio Technology Corporation

Address of License Holder : 8F.,No.653-2,Zhongzheng Rd., Xinzhuang Dist., New Taipei City 24257,Taiwan(R.O.C)

FCC Interference Statement

This equipment has been tested and found to comply with the limits for a Class B digital device, pursuant to Part 15 of the FCC Rules. These limits are designed to provide reasonable protection against harmful interference in a residential installation. This equipment generates, uses and can radiate radio frequency energy and, if not installed and used in accordance with the instructions, may cause harmful interference to radio communications. However, there is no guarantee that interference will not occur in a particular installation. If this equipment does cause harmful interference to radio or television reception, which can be determined by turning the equipment off and on, the user is

encouraged to try to correct the interference by one of the following measures:

- Reorient or relocate the receiving antenna.
- Increase the separation between the equipment and receiver.
- Connect the equipment into an outlet on a circuit different from that to which the receiver is connected.
- Consult the dealer or an experienced radio/TV technician for help.

This device complies with Part 15 of the FCC Rules. Operation is subject to the following two conditions:

- (1) This device may not cause harmful interference, and
- (2) This device must accept any interference received, including interference that may cause undesired operation.

FCC Caution: Any changes or modifications not expressly approved by the party responsible for compliance could void the user's authority to operate this equipment.

This transmitter must not be co-located or operating in conjunction with any other antenna or transmitter.